

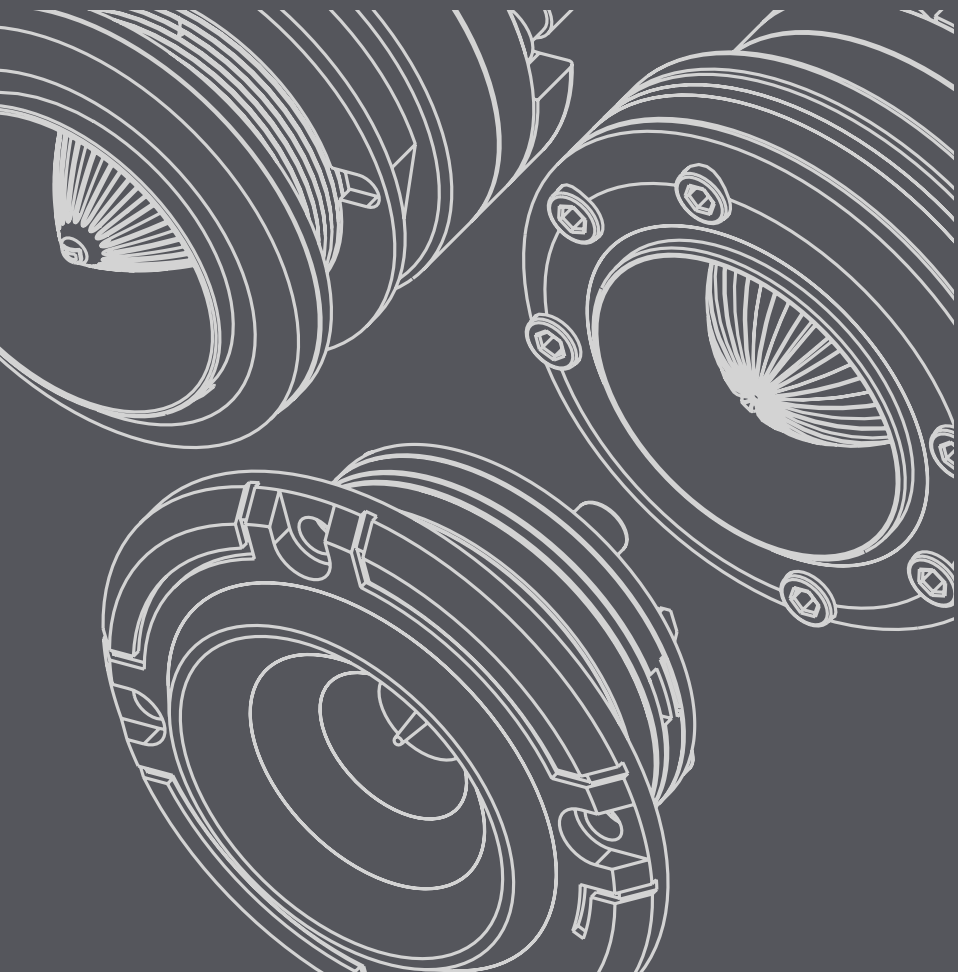

DIAMOND
AUDIO

M01T/M1SRT/M01SWT
M075T/M175T



Owners Manual



Congratulations, you have just purchased one of the finest mobile audio products on the market. Diamond Audio products represent the latest advances in acoustic technology in sound reproduction for your vehicle. Diamond Audio products are designed, developed, and engineered in the USA using the latest innovative materials and components to provide the finest sound reproduction possible. Every Diamond Audio product has been verified and tested to ensure the best sounding and most reliable product on the market, if installed properly. Diamond Audio products will provide many years of the ultimate listening experience.

Please note that prolonged exposure to sound pressure levels in excess of 100dB can cause permanent hearing loss. Using Diamond Audio products can exceed that level, so please exercise restraint in its operation in order to preserve your ability to enjoy its high fidelity sound for many years to come.

Diamond Audio recommends our products be professionally installed by an authorized Diamond Audio dealer to achieve the best possible system recommendation and installation. This will ensure a true Diamond Audio listening experience and sound you would expect from Diamond Audio products. With proper validation use a Diamond Audio Retailer for installation of your newly purchased amplifier. Diamond Audio will extend the product warranty from one year to Two Years!!

Go ahead, Hear the Music

MO1T/M1SRT/MO1SWT/MO75T/M175T (Pairs)

* What comes in the box*

- Pair of Pro Audio High Frequency drivers
- 12 dB Passive Crossover Included
- MO1T/M1SRT and M175T comes with 3 Mounting Rings included: Copper/Silver/Black
- 2 Rubber "Shock Absorber" Mounting Gaskets



Copper



Silver



Black

FEATURES/SPECIFICATIONS

The next generation of Diamond Audio Pro Audio High Frequency drivers features and specifications are on the next few pages. Makes sure to read this manual and get to know your drivers and the many applications and set up scenarios available to you. The M01T and M1ST have threaded horn bodies and come with 3 mounting bezels that thread on. Be careful to not strip them

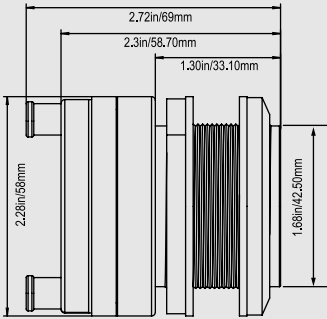
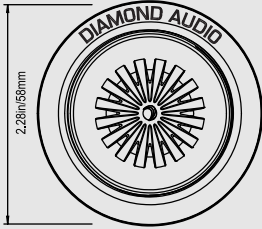

M01T

- 1" Pro Audio High Frequency drivers
- 50W/*100W MAX RMS Power Handling
- 107dB Sensitivity
- Composite Rubber Mounting Frame
- 12dB Crossover included for maximum protection
- Radial Slit Phase Plug for Better Response
- Re-buildable Diaphragm Replacement Design (part# MSPRO1STD)

**Hi-pass filtered @ 6000 Hz - 12 dB Oct

SPECIFICATIONS:

Sensitivity :	107 dB 1W/1M
Frequency Response :	3K-20KHZ
Nominal Impedance :	4 ohm
Cut-out Diameter :	1.75"/44.45mm
Front of Horn to Magnet Depth:	1.3"/33.1mm
Depth Front to Back Magnet:	2.3"/58.7mm
Over-All Diameter :	2.28"/57.9mm
Over-All Depth :	2.72"/69mm

M1SRT

- 1" Compression Extreme Output Tweeter - Short Horn Version
- 50W/*100W MAX RMS Power Handling
- 107dB Sensitivity
- Composite Rubber Mounting Frame
- 12dB Crossover included for maximum protection
- Radial Slit Phase Plug for Better Response
- Re-buildable Diaphragm Replacement Design (part# MSPRO1STD)

SPECIFICATIONS:

Sensitivity :	107 dB 1W/1M
Frequency Response :	3K-20KHZ
Nominal Impedance :	4 ohm
Cut-out Diameter :	1.75"/44.45mm
Front of Horn to Magnet Depth:	0.83"/21mm
Depth Front to Back Magnet:	2.3"/58.7mm
Over-All Diameter :	2.28"/57.9mm
Over-All Depth :	2.22"/56.4mm

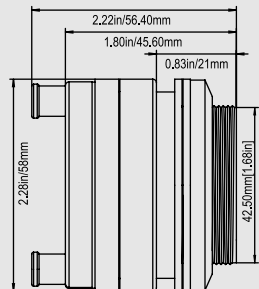

M075T

- 1" Compression Extreme Output Tweeter - Short Horn Version
- 50W/*100W MAX RMS Power Handling
- 107dB Sensitivity
- Composite Rubber Mounting Frame
- 12dB Crossover included for maximum protection
- Radial Slit Phase Plug for Better Response
- Re-buildable Diaphragm Replacement Design (part# MSPRO1STD)

SPECIFICATIONS:

Sensitivity :	107 dB 1W/1M
Frequency Response :	2.5K-20KHZ
Nominal Impedance :	4 ohm
Cut-out Diameter :	2.09" /53mm
Front of Horn to Magnet Depth :	0.39" /10mm
Depth Front to Back Magnet :	1.38" /35mm
Over-All Diameter :	2.95" /75mm
Over-All Depth :	1.57" /38.8mm

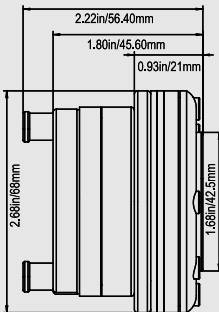
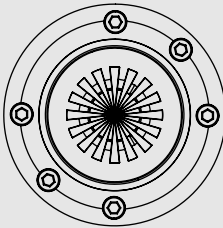
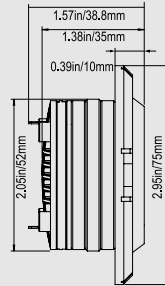
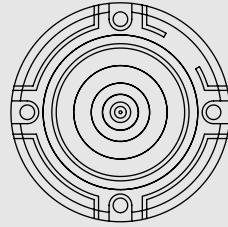

M01SWT

- 1" Compression Extreme Output Tweeter
- 50W/*100W MAX RMS Power Handling
- 107dB Sensitivity
- Composite Rubber Mounting Frame
- 12dB Crossover included for maximum protection
- Radial Slit Phase Plug for Better Response
- Re-buildable Diaphragm Replacement Design (part# MSPRO1STD)

**Hi-pass filtered @ 6000 Hz - 12 dB Oct

SPECIFICATIONS:

Sensitivity :	107 dB 1W/1M
Frequency Response :	2K-20KHZ
Nominal Impedance :	4 ohm
Front of Horn to Magnet Depth :	0.93" /23.6mm
Depth Front to Back Magnet :	2.3" /58.7mm
Cut-out Diameter :	1.91" /48.5mm
Over-All Diameter :	2.68" /68mm
Over-All Depth :	2.22" /56.40mm

SPECIAL MOUNTING AND SETUP FOR M01SWT SWIVEL MOUNT

The next generation of Diamond Audio Pro Audio High Frequency drivers adds an exciting twist (swivel) to the NEW line of horn tweeters. Below is how to disassemble and reassemble the tweeter. Its different than our M01T tweeter in that it does NOT have threaded mounting rings. And MUST be mounted with 6 holes in whatever sub structure you are mounting it to. A much more solid mount, but more thought has to be in the setup. The advantage is the the tweeter can be swiveled slightly into the direction of the driver. Giving better "on-axis" listening response.

M01SWT

SWIVEL MOUNT 1" HORN TWEETER ASSEMBLY

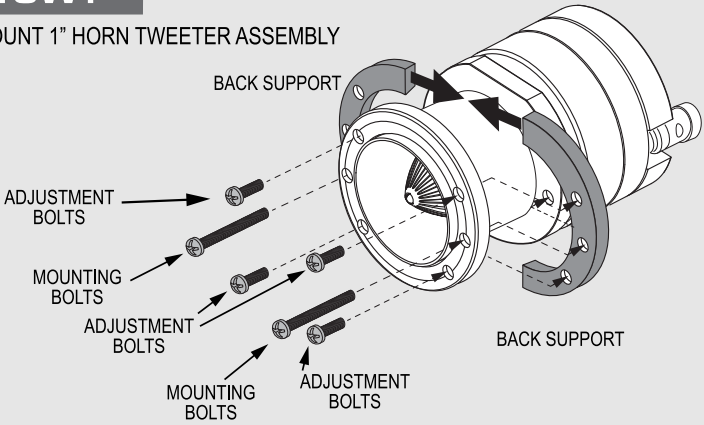

MOUNTING THE SWIVEL MOUNT HORN TWEETER - AND ADJUSTMENT

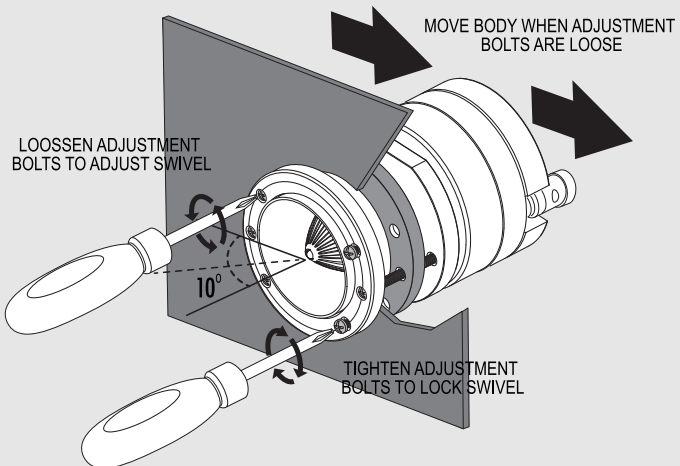

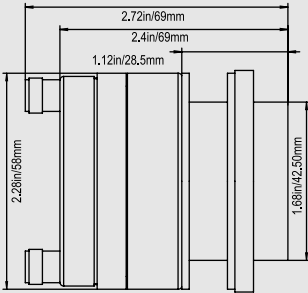

M175T

- 1" Compression Extreme Output Tweeter
- 50W/*100W MAX RMS Power Handling
- 107dB Sensitivity
- Composite Rubber Mounting Frame
- 12dB Crossover included for maximum protection
- Radial Slit Phase Plug for Better Response
- Re-buildable Diaphragm Replacement Design (part# MSPRO1STD)

**Hi-pass filtered @ 6000 Hz - 12 dB Oct

SPECIFICATIONS:

Sensitivity:	107dB 1W/1M
Frequency Response:	3K-20K HZ
Nominal Impedance:	4 ohm
Front of Horn to Magnet Depth:	1.12" /28.5mm
Depth Front to Back Magnet:	2.4" /69mm
Cut-out Diameter:	1.72"
Over-All Diameter:	2.28"
Over-All Depth:	2.72"

MOUNTING THE M175T HORN TWEETER - WITH BOLTS

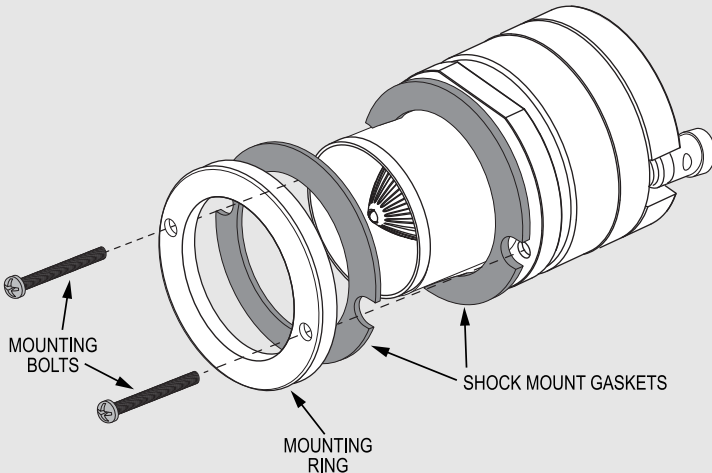

TWEETER DIAPHRAM INSTALLATION

TWEETER/DIAPHRAGM DIS-ASSEMBLY DRAWING

Replacement Design (part# MSPRO1STD)

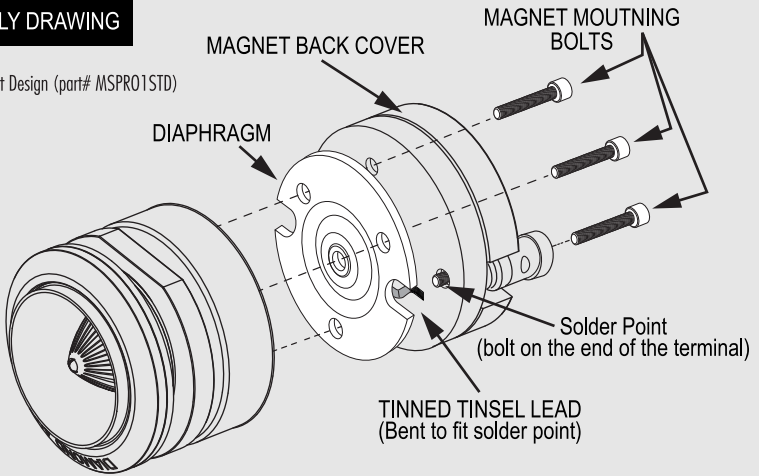

Replacement Tweeter Diaphragms **MSPRO1STD**

MSPRO1STD - 1" REPLACEMENT TWEETER DIAPHRAGM

TWEETER/DIAPHRAGM SOLDERING - RE-ASSEMBLY DRAWING

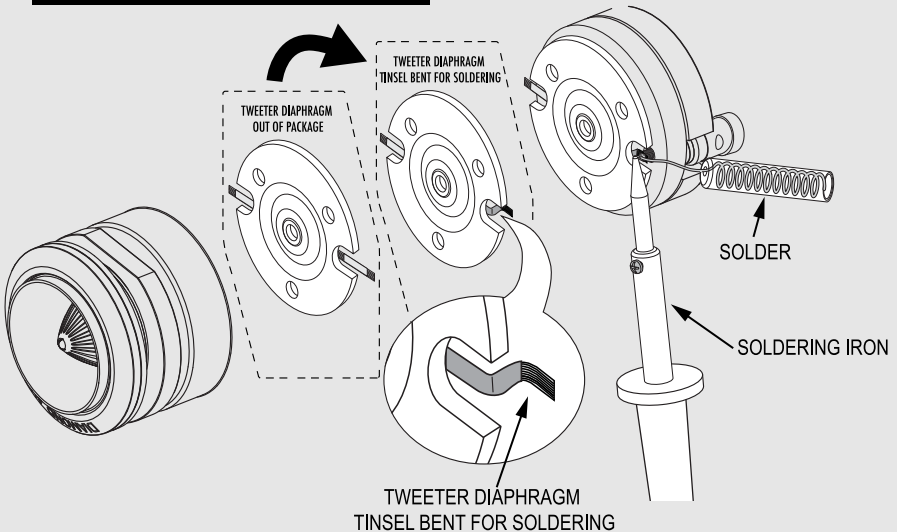

All MSPRO Horn Tweeters comes with a special 12dB per octave crossover. It is HIGHLY recommended that this be used at ALL times - UNLESS you are using an active crossover set at above 5kHz. This system, shown is "Bi-Amped, but not 'Fully' active. Front channels of this 4 channel amplifier are driving the mid bass drivers. Rear channel are driving the tweeters. The mid bass is shown with a 0.1mH inductor in series to cross over the midbass at 6KHz with a 6dB roll-off. This setup makes it easier to adjust level of ths midbass versus the tweeter.

TYPICAL "BI-AMPED" SYSTEM USING PASSIVE CROSSOVERS

**** SPECIAL NOTE ****

Tweeter connected "out-of-phase" to be acoustically "in-Phase"

**** SUPER SPECIAL NOTE ****

Make sure to connect the cap side of crossover to the amplifier!!!

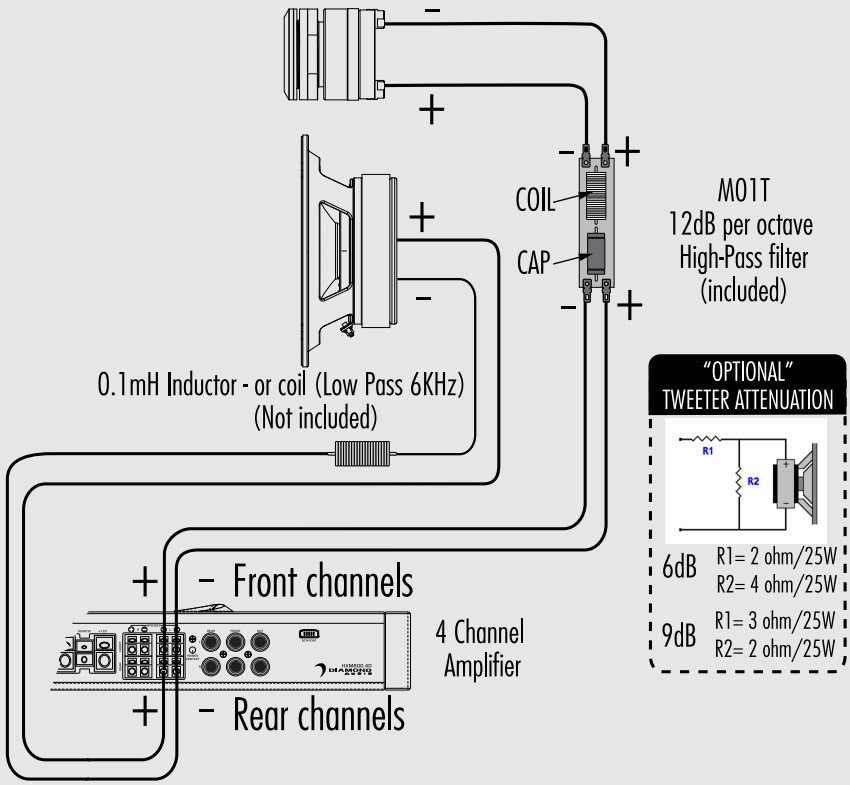

SYSTEM DESIGN - FULLY ACTIVE

The MSPRO series horn tweeters and Midbass drivers can be run in multiple pairs. It is HIGHLY recommended to use some kind of EQ/processor. IF you plan on doing ALL active setup seriously think about purchasing a DSP processor. Using a DSP processor makes it much easier to control and tune your system. Think about using the Diamond Audio DSP processor - BTDSP-46. Small 4 in 6 out DSP processor, simple to use. Controlled and setup by your SmartPhone

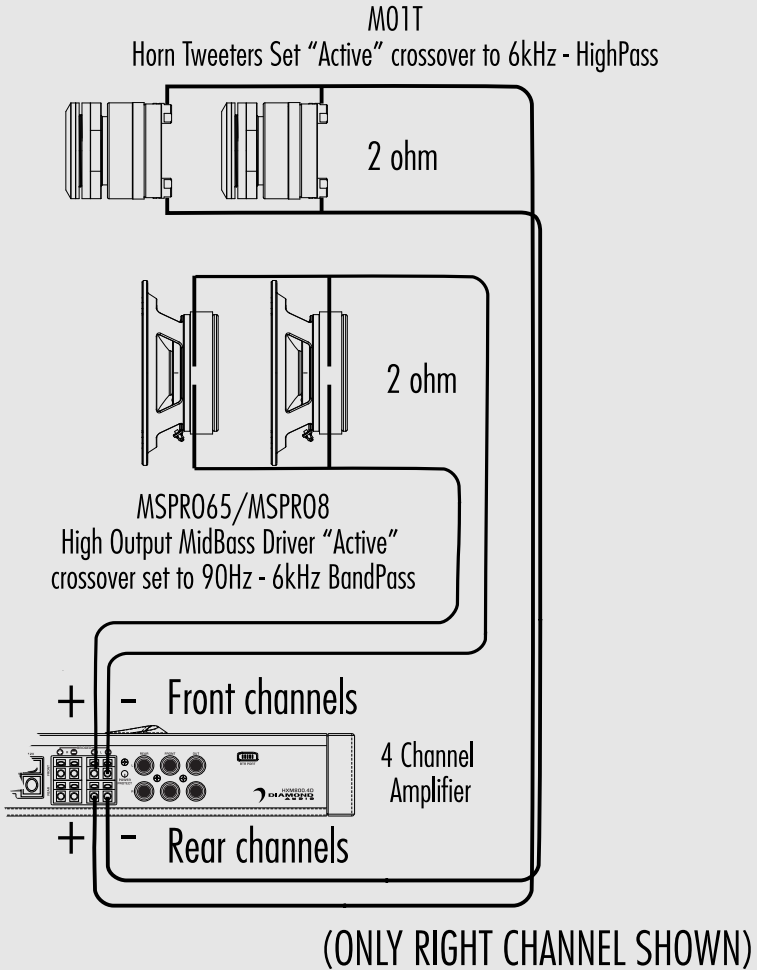

Installing the Speakers

Your new Diamond Audio series speakers were designed with the flexibility to be installed in multiple locations. However, to ensure the best performance possible, it is important to isolate the front sound waves of the speaker from its rear sound waves. This is done by securely mounting the speaker to a flat surface known as a baffle. Make sure to seal the speaker to ensure there are no air leaks around its frame.

Selecting a Location

Since these are "Pro Drivers" we know the likelihood of mounting in stock locations is pretty non-existent. This means basic audio concepts should be thought of when installing. If installing multiple midbass or tweeter drivers it is ALWAYS best to mount in vertical rows. This gives the best vertical and horizontal dispersion characteristics of the drivers. Venting (or porting) is not necessary. Multiple midbass drivers should be used to every single horn driver (horn tweeters tend to be 10dB louder than the mids).

We HIGHLY recommend that for the BEST sound you put a sound deadening mat on the door "skin", The more "damped" your car is.... the better it will ultimately sound!!!

Dimension	Unit	M01T	M1SRT	M01SWT	MO75T	M175T
Overall Diameter (A)	in. (mm)	2.28 (57.9)	2.28 (58)	2.28 (58)	2.28 (58)	2.28 (58)
Cut Out Diameter (B)	in. (mm)	1.75 (44.45)	1.75 (44.45)	1.61 (41)	1.61 (41)	1.61 (41)
Overall Depth (C)	in. (mm)	2.72 (69)	2.22 (56.4)	2.22(56.40)	2.0 (50.8)	2.0 (50.8)
Depth Front to Back Magnet (D)	in. (mm)	2.3 (58.7)	2.38 (60.55)	2.3(58.7)	1.38(35)	2.38 (60.55)
Front of Horn to Magnet Depth (E)	in. (mm)	1.3(33.1)	0.83(21mm)	0.93(23.6)	1.57(38.8)	1.12(28.5)

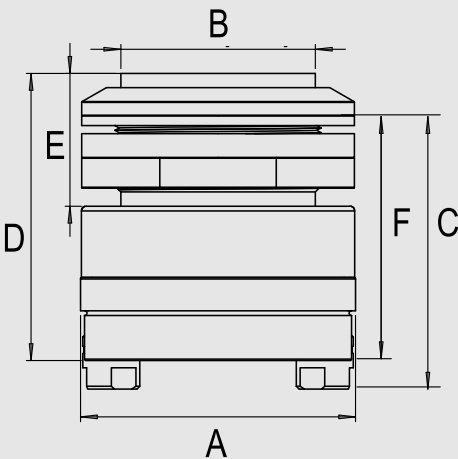

WARRANTY

Diamond Audio Technologies (DAT), a division of CV & DA Holdings Incorporated, warrants this product to be free from defects in material and workmanship for a period of one (1) year from the original date of purchase, provided it was purchased from an authorized DAT retailer within the United States. Product warranty period starts at the date of purchase or one year past the manufacture date whichever is first. However, upon purchase and completion of the on-line registration and installation by an authorized DAT dealer, warranty period will be extended to two (2) years. This warranty extension offer will only be recognized upon completion of the on-line registration of your product within thirty (30) days of the date of purchase.

THIS WARRANTY IS NOT TRANSFERABLE AND APPLIES ONLY TO THE ORIGINAL PURCHASER OF THIS PRODUCT IN ITS ORIGINAL INSTALLATION. Original purchaser must reside in the United States and be able to provide proof of purchase and installation with the sales receipt and completion of online registration from the authorized DAT retailer that sold and installed the product.

Should a manufacturing defect occur during above said warranty period, DAT will replace or repair the defective product with a product of the same or equivalent value and performance, at DAT's discretion.

Damage or failure caused by any of the following is not covered under this warranty policy: negligence, improper use, abuse, product modification, unauthorized repair attempts, accident, acts of God, misrepresentations by DAT retailers, and improper/inadequate packaging during return shipping.

Warranty is void if serial numbers have been removed, altered or defaced.

HOW TO OBTAIN WARRANTY SERVICE

In the event a DAT product should require service, you should visit the authorized DAT retailer you purchased the product from and they can expedite your claim. All claims must fall into the guidelines listed above and be accompanied by a copy of the original sales and installation receipt from that authorized DAT retailer.

Product returned for warranty service must be freight-prepaid, properly packaged and clearly marked with the Return Authorization (RA) number issued by DAT. Any product returned to DAT that is improperly packaged, does not have a RA number clearly marked on the package, or never received a RA number, may be refused upon delivery. DAT does not assume responsibility for lost or misdirected product.

Repair or replacement under this warranty is the exclusive remedy of the consumer. DAT shall not be liable for any incidental or consequential damages for breach of any expressed or implied warranty on this product. Some states do not allow the exclusion or limitation of incidental or consequential damages, or allow limitations on how long an implied warranty lasts, so the above limitations or exclusions may not apply to you. This warranty gives you specific legal rights and you may also have other rights that may vary from state to state.

Customers outside the United States should contact their local sales office to obtain information on pricing, exchange unit availability, instructions, service and warranty/non-warranty replacement or repair.

Diamond Audio Technologies

3761 S. Hill Street
LOS ANGELES, CA 90007
Tel: 213-261-4161
Fax: 213-947-4767
Web: diamondaudio.com

Service/Tech Support:

213-261-4161
Tech Support Email
helpdesk@dat-cvm.com



DIAMOND
AUDIO

3761 S. Hill Street
Los Angeles, CA 90007

©2019 Diamond Audio. All rights reserved.
(a division of CV & DA Holdings, Inc.)