

RYKER FRONT FENDERZ SAFETY REFLECTOR LED

KIT 1 AMBER ONLY



KIT 1 INCLUDES

- 1 pair of amber with sequential turn
- 1 pair of quick connect harness
- 2 pcs of adhesive line shrink tube
- 1 alcohol pads
- 1 primer

KIT 2 AMBER AND RED



KIT 2 INCLUDES

- 1 pair of amber with sequential turn
- 1 pair of red reflector LED
- 1 pair of quick connect harness
- 1 pair of 1:2 splitter
- 2 pcs of adhesive line shrink tube
- 1 alcohol pads
- 2 primer



Use masking tape to cover the top A arm.



Using a 13mm socket, remove the 4 fender bolts.



Slide fender over to the inside of the bike



Use heat gun warm up the yellow reflector, and remove



Use a Torx 20 bit to remove the screw behind the yellow reflector



From the underside near the front remove the 2 torx 20 screw that holds the front tip light



Use a pry tool to release the small tab from the bottom front fender that holds the tip LED



Gently pull out the fender tip light

RYKER FRONT FENDERZ SAFETY REFLECTOR LED



Push down on the tab to release wire clip



Remove fender tip light

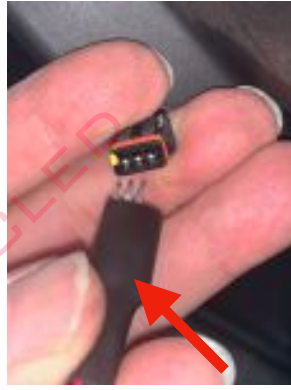

Slide the shrink tube thru the wire harness supplied with the pins exposed

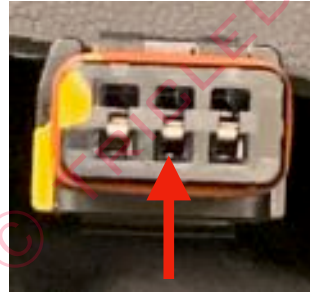

APPLY DI ELECTRIC GREASE TO ALL CONNECTIONS

Insert the supplied pin harness into the factory harness. Note the slots where the pins are inserted has metal pin.



When sliding in the supplied pin into the OEM harness, line up red wire pin to red wire on OEM harness.



Push the start button to test the light and also test the turn signal. (note if you push the start button and the amber light starts to do a sequential means your pins are reversed, fix before continuing



Slide the shrink tube over the pins and into the Oem connector as far as it will go up. Use heat gun or lighter to shrink the tube tightly, let it sit for a few minutes to cool and hardens



Position the new yellow LED over the mounting position and mark for the wire hole to be drilled. Drill large enough for connector to pass through. Clean surface with alcohol supplied, let dry. Apply the primer tube to the area and let dry. Peel off backing and adhere LED to the fender and press firmly. Be sure to warm up the adhesive if your installing in temperature cooler than 70 degrees for maximum adhesion



From the bottom of the fender pull wire out to the side of the pocket opening to make your connections. This will make it easier to access.

APPLY DI ELECTRIC GREASE TO ALL CONNECTIONS

RYKER FRONT FENDERZ SAFETY REFLECTOR LED

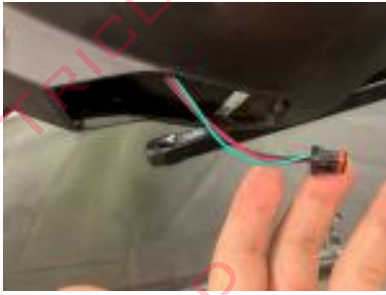

Pull the female part of the harness out the front.



Connect the female pin into the tip LED until it clicks



Slide the tip light back in and make sure wire is not pinched and slides back. Push tip light until it snaps back and locks into position



Wrap the connectors with electrical tape to protect it



Tuck the wires back inside the pocket. Be sure to not pinch or kink any of the connectors



Put back the 2 screws on the bottom of the fender into the tip light

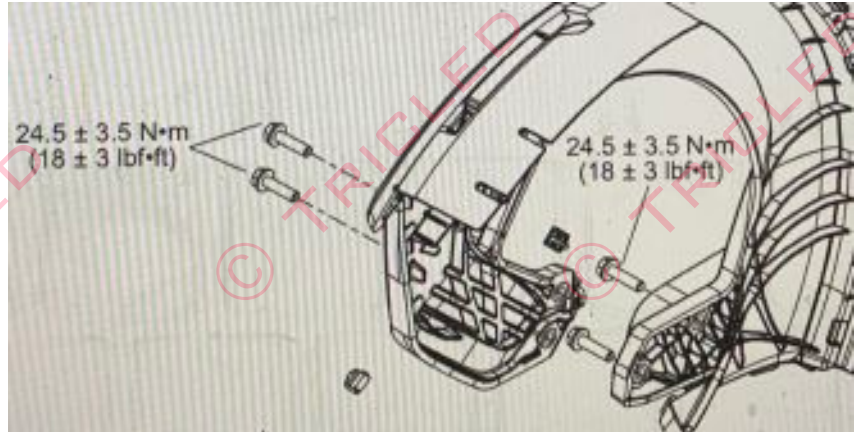

If you are not installing the red rear reflectors then you are ready to put the fender back on. Line up the bolt holes and tighten each bolt by hand first until snug before tightening.

Owners manual suggest 18 ± 3 lbf•ft

IF YOU ARE INSTALLING THE RED LED REFLECTOR ALSO PLEASE CONTINUE AND FOLLOW THIS MANUAL

RYKER FRONT FENDERZ SAFETY REFLECTOR LED



Position the new red reflector over the factory sticker.

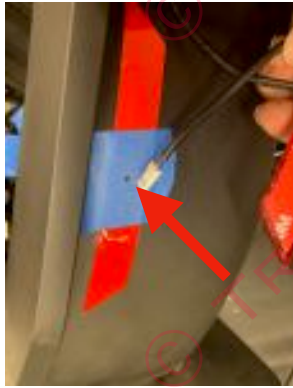

Use a masking tape and mark the position of the wire



Drill a hole large enough to pass the connector



Clean the surface with alcohol and let dry



Apply primer and let dry



Peel the protective backing and apply red LED to fender



Wire from red reflector to the inside of the fender. Drill the ridge between fender and inside fender wall so that you can secure the red reflector wire along the fender to the front.



WIRE FROM RED REFLECTOR

Drill along the ridge and insert zip tie and run red reflector wire along the ridge and secure



TUCK WIRE BEHIND RIDGE AND ZIP TIE

RYKER FRONT FENDERZ SAFETY REFLECTOR LED



Use 1:2 splitter and connect red and yellow reflector LED. Be sure to use Di-Electric grease. Push the start button and test the lights and turn signal

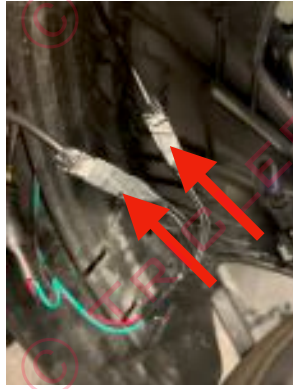

Use electrical tape to seal the connectors



Gently tuck in the wires under the front tip light pocket



Recommended step here is to clean the bottom of the fender well with alcohol thoroughly, use a black gorilla tape to seal the bottom pocket where the wire is stored to protect it from water and debris.



Apply same for the red reflector, clean surface thoroughly with alcohol and apply a piece of black gorilla tape to keep it flushed to the fender and keep wires up against the fender. When finished replace back the fender and all the bolts and tighten to factory specs.



CONGRATULATIONS, YOU HAVE JUST INSTALLED ONE OF THE BEST SAFETY ITEMS ON YOUR RYKER. STAY SAFE AND BE SEEN. THANK YOU FOR YOUR PURCHASE