

AIR AND ELECTRICAL CONTROLS (FRONT AND REAR)

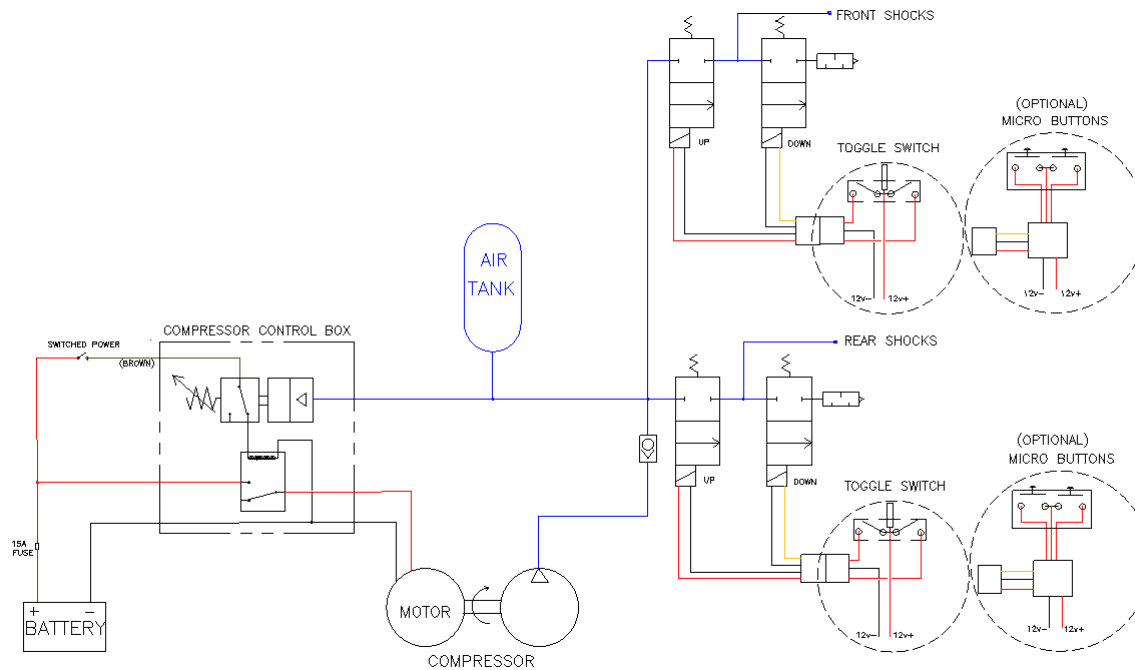

AIR CONNECTIONS

1. AirFX uses 5/32 OD Nylon tubing and push to connect style fittings. To release the tube from the fitting, simply push down on the plastic clutch ring and pull out the tubing.
2. Cut a length of tubing and connect from the compressor fitting to the straight fitting on the rear solenoid valve pair. (Valve pair with brass fitting)
3. Cut a length of tubing and connect from the swivel elbow on the rear valve pair to the tee fittings. Connect the air tank, compressor control box, and front valve pair to the tee fittings.
4. Connect the fitting between the rear valve pair to the rear shock or to the tee fitting feeding the rear shock pair.
5. Connect the fitting between the front valve pair to the tee fitting feeding the front shocks.

ELECTRICAL CONNECTIONS

1. Connect the leads from both switch wiring harnesses to 15A fused power, red and black wires.
2. Connect the four leads from the white connector, one black wire and the red wire to one solenoid valve, one black wire and the orange or white wire to the other solenoid valve. Repeat for the 2nd switch wiring harness
3. Plug the white mating connectors together. Wrap the connectors with electrical tape.
4. Make the compressor control box connections. Fused (15A) power to the red and black wires labeled BAT + and BAT -. Black and red wires labeled COMP + and COMP- to the compressor leads. Brown wire labeled ignition to power source that is ON when the key switch is ON.

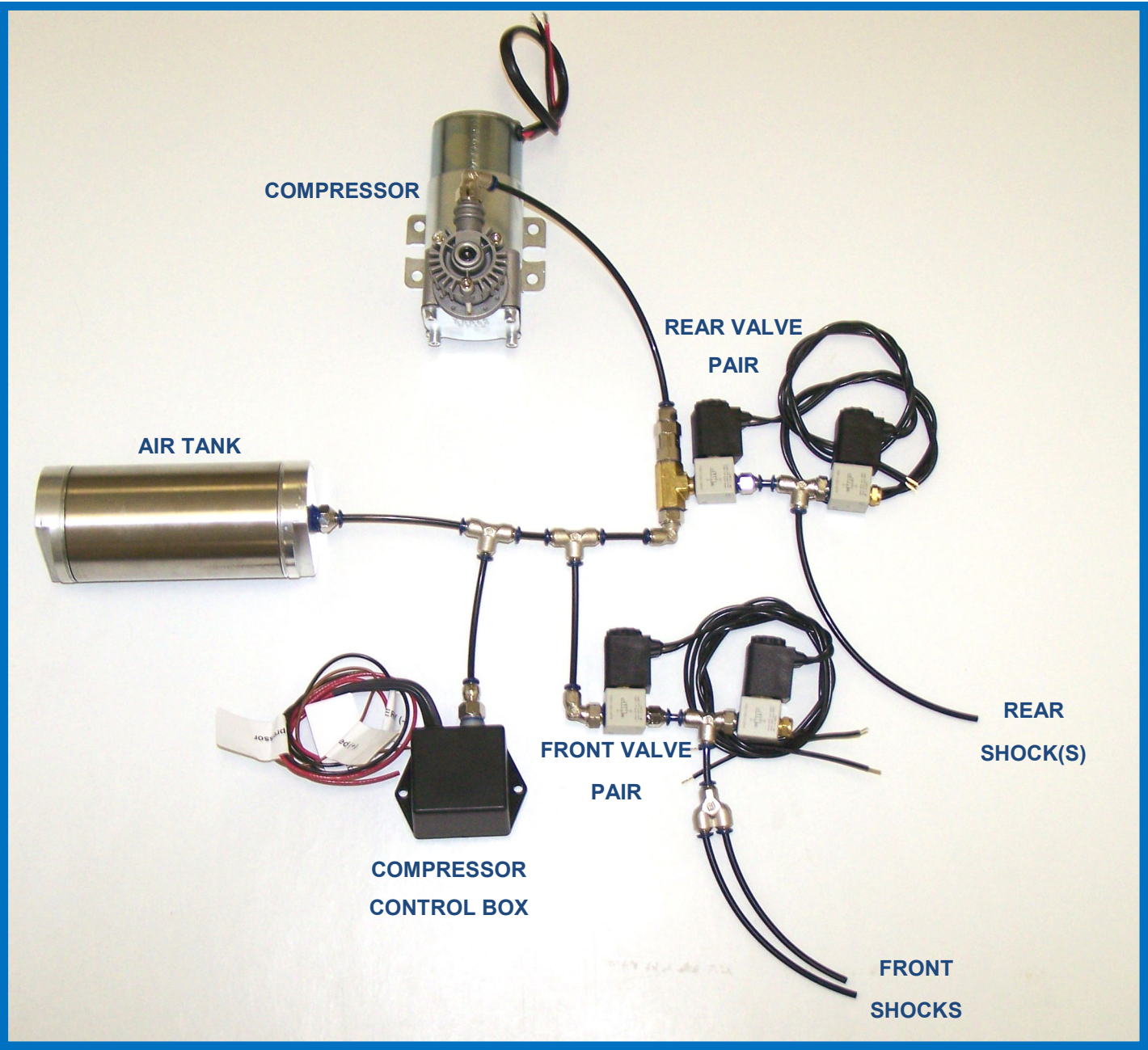

COMPRESSOR

AIR TANK

REAR VALVE
PAIR

COMPRESSOR
CONTROL BOX

FRONT VALVE
PAIR

REAR
SHOCK(S)

FRONT
SHOCKS