



DIAMOND
AUDIO

MSHR2/MSHR4

**HARLEY-DAVIDSON®
BAGGER - 2/4 CHANNEL
WIRING HARNESS/KIT**

(Fits All Harley Baggers 1998 through 2019)



Owners Manual

INSTALL GUIDE:

Congratulations, you have just purchased one of the finest mobile audio products on the market. Diamond Audio products represent the latest advances in acoustic technology in sound reproduction for your vehicle. Diamond Audio products are designed, developed, and engineered in the USA using the latest innovative materials and components to provide the finest sound reproduction possible. Every Diamond Audio product has been verified and tested to ensure the best sounding and most reliable product on the market, if installed properly. Diamond Audio products will provide many years of the ultimate listening experience.

Diamond Audio recommends our products be professionally installed by an authorized Diamond Audio dealer to achieve the best possible system recommendation and installation. This will ensure a true Diamond Audio listening experience and sound you would expect from Diamond Audio products. With proper validation use a Diamond Audio Retailer for installation of your newly purchased amplifier. Diamond Audio will extend the product warranty from one year to Two Years!!

Go ahead, Hear the Music

MSHR2/MSHR4 - BAGGER 2/4 CHANNEL AUDIO WIRING KIT

2 channel version is for speakers in bags only with 2 channels of signal RCA. Comes with speaker harnesses for both bags, and 2 channels of RCA.
4 channel version is for speakers in fairing (or lowers) and speakers in bags, with 4 channels of signal RCA.

Fitment: All Harley baggers 1998 through 2019

- 8 gauge power and ground battery connections
- Waterproof fuse holder includes 2 pcs- 20A ATC fuses and Allen key for service.
- Heavy duty power quick disconnects
- Quality Shielded OFC RCAs with quick disconnects included
- All cable runs are blacked out, loomed, & terminated for you.
- Stainless steel chrome plated wire inlets for both saddlebags included
- Speaker terminal assortment, amplifier power & speaker terminal forks included
- Zip ties included
- Amplifier remote turn-on integrated into quick disconnect harness
- No special tools needed for installation
- SAVES TIME!!!

INSTALL GUIDE:

This amplifier wire harness makes it quick and easy to properly install a power amplifier inside a Harley Davidson saddlebag. The wire harness will work equally as well with an amplifier mounted on the left or right side saddlebag. In the instructions below we assume that the amplifier will be mounted in the left saddlebag but it will work in either bag.

GENERAL INSTALLATION OVERVIEW

The amplifier wire harness is made up of a power harness and a signal harness. Both of these harnesses have two parts. One side of each harness is installed onto the bike, the other side of each harness is installed onto the saddlebag containing the power amplifier.

4 MAIN PARTS TO HARNESS

Before you begin the installation, identify the amplifier wire harness parts.

- power harness bike side (with ring terminals and fuse holder) and bag side
- Fuse holder should be placed underneath plastic side cover located in front of the saddlebag that amplifier is being installed into.
- The power quick connect should be located under the plastic side cover, Make sure to give it some slack,...BUT not too much as it will be unmanageable

NOTE: Take care to route battery cable and not get it pinched as this will cause a possible short and a fire hazard. The bag side of the harness will run from the connection point under the side cover to the saddlebag with an amplifier.

IDENTIFYING THE POWER HARNESS

The signal harness bag side only has one master plug but the bike side has 2 plugs the large plug on the bike side should be located under the side cover, and like the power harnesses it should have some slack, but not too much so it is unmanageable.

DISASSEMBLE THE BIKE

Starting installation - First, remove gas tank then remove plastic wire channel cover located under the gas tank. Remove the outer fairing at the front of the bike to gain access to the rear of the radio.

INSTALL GUIDE:

Tip: Leave the gas tank off of the bike until the very end of the installation. You will need access to the cables running under the gas tank to the fairing so that you can adjust their position during the installation.

Remove the saddlebag that the amplifier will be installed into. Then remove the side panel cover that is located in front of the saddlebag that the amplifier will be located in. Remove the second saddlebag and side cover.

ROUTE THE CABLES ON THE BIKE

Position the main Multi-Pin plug of the bike side signal harness under the side cover location so that there is no extra slack and so that there is room to tuck it away under the side cover. Too much slack and the side cover will be difficult to put back in place at the end of the installation! You want just the right amount of slack so that the saddlebag can be unfastened, leaned outward (resting on your leg) and that the side panel in front of the saddlebag can be removed and the harness connected/disconnected. Route all wire harness cables into the battery compartment.

Tip: remove the two large Torx bolts that fasten the fuse box panel to the bike. Cut the large zip tie that holds the fuse box wire harness to the back of the fuse box panel. This will allow you to pull the entire fuse box assembly away from the bike and route your cables in and out of the battery area. When you are finished with your installation, obtain a new large zip tie and replace the one you cut off.

INSTALL THE POWER HARNESS (NIKE SIDE)

Find a spot under the side cover area for the fuse holder to reside. On the left side (fuse box side) there is an empty area in front of the fuse box. On the right side of the bike, there is an area in front of or below the ABS module. Bikes without ABS brakes have lots of room under the right side cover panel. Route the power cables with ring terminal ends into the battery area and connect to the battery. Warning! Take care not to route the battery cables in a manner that will allow them to become pinched and possibly shorted to the bike frame. This will cause a fire hazard.

2 PIN SPEAKER HARNESS

The bike side signal harness has a sub-harness with a two-pin connector on it. This is the speaker output from the bag containing the amplifier to the saddlebag that does not contain an amplifier. This allows the lid speaker in the bag not containing an amplifier to be powered by the amplifier in the opposite bag and for that second bag to have a disconnect point from the bike.

INSTALL GUIDE:

Route the 2 conductor speaker wire harness with a 2 pin plug across the battery compartment into the side cover area on the opposite side of the bike, This is the speaker wire for the second saddlebag. All the rest of the signal cable RCA, remote turn on and front speaker wires (4 channel harness ONLY) route up to the front fairing.

SADDLEBAG WIRE HARNESS INSTALLATION

Tip: The black speaker wire cables in this kit tend to hold the shape of the coil they are in when packaged. The black jacket on these cables can be straightened out easily by warming them up with a heat gun and holding them straight. This is easier done with a second person to hold the harness. Once straightened the cables will want to hold that straight shape and will be much easier to deal with during installation. Don't get the braided loom too hot or it will melt and look funky!

Drill an entry point hole where the wiring harness comes in. The exact location is not critical but we recommend locating it on the inside wall 1.5 in from the front wall and 1.5 from the bottom. Hole diameter should be only as large as necessary to bring all RCA cables, power cables, and speaker wire thru. Typically smaller than a 1 inch. The length of the harness exiting from this hole should be about 14 inches from the exit point on the bag to the connector where it plugs into the bike. Install the chrome wire clamp with the #4 screw provided Pre Drill 3/32 hole (#4 screw). Run the bag side of the power harness in with the rest of the signal harness.

The chrome wire clamps should be installed so they point down and towards the back of the bag at about 25 degrees. You want the wire harness to point slightly backward so that the wire forms a half loop before it runs towards the front of the bike (side cover). This keeps some tension on the wire length and allows for enough give (slack) in the harness assembly to be serviceable and easily managed. Temporarily mount the bag with the wire harness in place. Now adjust the wire exiting the bag and the bike side wire harness position so that the wire harness plugs can connect and will fit under the side cover location.

INSTALL THE AMPLIFIER

Once the wire harness has been installed into the saddlebag and the harness position has been finalized, its time to install the amplifier. Find a suitable location inside the saddlebag for the amplifier and mount the amplifier in place. Route the amplifier wire harness so that it reaches all of the various connection points of the amplifier. Be sure to leave enough slack in the harness so that the amplifier will be serviceable. Cut the power, speaker, and remote cables down to a suitable length.

INSTALL GUIDE:

Tip: route the wire under the lid tether and then zip tie the speaker cable to the saddlebag. There is a thin rib that runs from front to back on the inside of the saddlebag. Use a 1/8" drill bit to drill a hole or two in this rib. Use the hole to zip tie the cable to the bag. Route the cable to the back of the bag even if the amplifier is mounted towards the front of the bag. Allow the speaker cable to run down to the far back corner of the bag and then loop it back up front to the amplifier. This will keep the cable well hidden and out of the way of bag daily use. This is why we make this part of the wire harness so long.

Use the supplied two conductor speaker wire harness to run from the lid speaker in the same bag as the amplifier down to the amplifier and connect to the amplifier speaker output for that channel. At the front of the bike

4 channel version harnesses have two channels (4 conductors) that run to the front speakers.

On-Road Kings ONLY (bikes without fairings) the remote wire should be connected to the battery fuse box to accessory power connection. It is recommended that you obtain a fuse tap from your local automotive parts store for this connection. Road Kings use the same fuse box as the fairing bikes. The radio/accessory circuit is present in the fuse box but the output terminal is not. So there will be only one pin in the radio fuse slot and that pin will power up with the bike's accessory. On all other bikes, the rest of the wiring needs to go to the front fairing.

Install the speaker wire harness to the second saddlebag in the same fashion as the first bag (no amplifier mounted here) Adjust wire harness exiting the saddlebag and the wire harness position on the bike side so they can mate together and fit under the side panel cover location. The length of this cable from the exit point of the bag to the 2 pin plug is also about 14".

Make connections to the speakers in the second saddlebag (one without the amplifier) and adjust wire length as needed inside the bag.

**If you do NOT know how to disassemble your bike
...go to a professional!!!**

2 Channel Wiring

NOTE : Colors shown are to help wiring the bike. They are THE actual colors in the harness itself

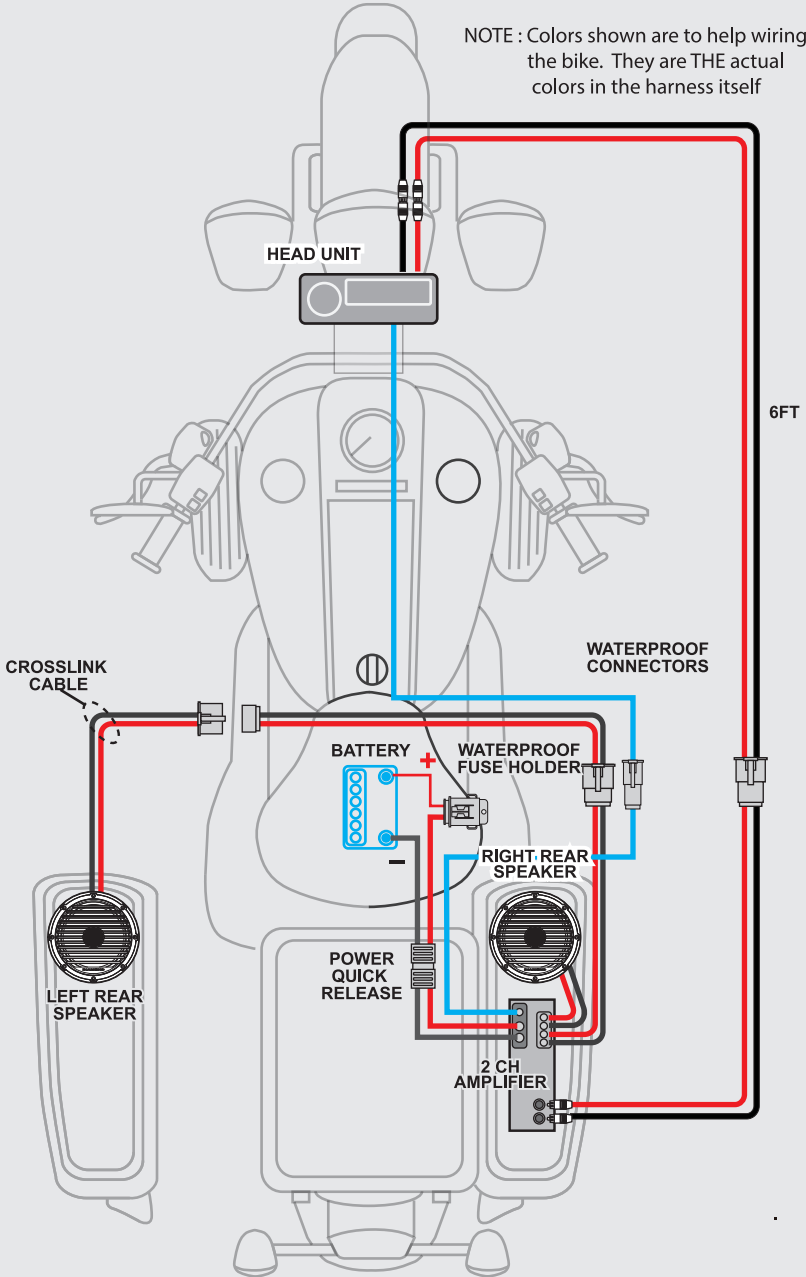

4 Channel Wiring

NOTE : Colors shown are to help wiring the bike. They are THE actual colors in the harness itself

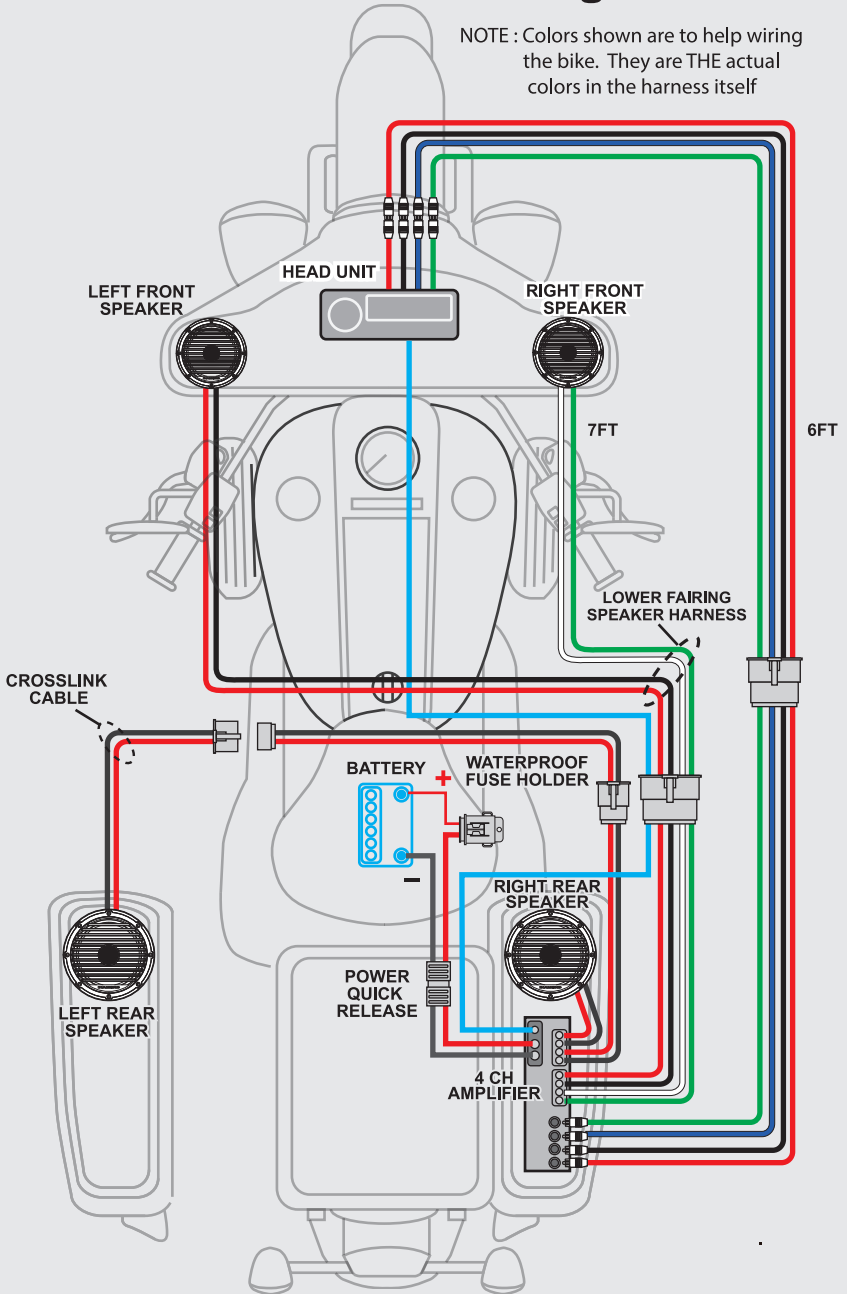

WARRANTY

Diamond Audio Technologies (DAT), a division of CV & DA Holdings Incorporated, warrants this product to be free from defects in material and workmanship for a period of one (1) year from the original date of purchase, provided it was purchased from an authorized DAT retailer within the United States. Product warranty period starts at the date of purchase or one year past the manufacture date whichever is first. However, upon purchase and completion of the on-line registration and installation by an authorized DAT dealer, warranty period will be extended to two (2) years. This warranty extension offer will only be recognized upon completion of the on-line registration of your product within thirty (30) days of the date of purchase.

THIS WARRANTY IS NOT TRANSFERABLE AND APPLIES ONLY TO THE ORIGINAL PURCHASER OF THIS PRODUCT IN ITS ORIGINAL INSTALLATION. Original purchaser must reside in the United States and be able to provide proof of purchase and installation with the sales receipt and completion of online registration from the authorized DAT retailer that sold and installed the product.

Should a manufacturing defect occur during above said warranty period, DAT will replace or repair the defective product with a product of the same or equivalent value and performance, at DAT's discretion.

Damage or failure caused by any of the following is not covered under this warranty policy: negligence, improper use, abuse, product modification, unauthorized repair attempts, accident, acts of God, misrepresentations by DAT retailers, and improper/inadequate packaging during return shipping.

Warranty is void if serial numbers have been removed, altered or defaced.

HOW TO OBTAIN WARRANTY SERVICE

In the event a DAT product should require service, you should visit the authorized DAT retailer you purchased the product from and they can expedite your claim. All claims must fall into the guidelines listed above and be accompanied by a copy of the original sales and installation receipt from that authorized DAT retailer.

Product returned for warranty service must be freight-prepaid, properly packaged and clearly marked with the Return Authorization (RA) number issued by DAT. Any product returned to DAT that is improperly packaged, does not have a RA number clearly marked on the package, or never received a RA number, may be refused upon delivery. DAT does not assume responsibility for lost or misdirected product.

Repair or replacement under this warranty is the exclusive remedy of the consumer. DAT shall not be liable for any incidental or consequential damages for breach of any expressed or implied warranty on this product. Some states do not allow the exclusion or limitation of incidental or consequential damages, or allow limitations on how long an implied warranty lasts, so the above limitations or exclusions may not apply to you. This warranty gives you specific legal rights and you may also have other rights that may vary from state to state.

Customers outside the United States should contact their local sales office to obtain information on pricing, exchange unit availability, instructions, service and warranty/non-warranty replacement or repair.

Diamond Audio Technologies

3761 South Hill Street
LOS ANGELES, CA 90007
Tel: 213-261-4161
Fax: 213-947-4767
Web: diamondaudio.com

Service/Tech Support:

213-261-4161
Tech Support Email
helpdesk@dat-cvm.com



DIAMOND
AUDIO

3761 S. Hill Street
Los Angeles, CA. 90007
Tech Support Direct: 213-212-3187

www.DiamondAudio.com

Designed in Conjunction with:

ROB GOMEZ

